

# PC100S-RCD Portable Series Crimper

## CAPABILITY

- (-16) B2 Fittings
- (-08) SG Fittings

## TECHNICAL DATA

- **CRIMPING FORCE** 35 Ton
- **WEIGHT** 48 lbs. (crimper only)
- **DIMENSIONS** 12-½" L x 12-½" W x 21-½" H
- **DIE SERIES** PC125RCD



SAP #	Pump	PSI	Reservoir Capacity	Country Approved	Dies Included	Die Sizes (MM)	Quick Disconnect Included	Shelf Included
21063190	Pneumatic	10,000	100 cu in (1,639 cc)	Any	(7)	12, 16, 19, 23, 27, 31, 43	✓	✓
21063169	Hand	10,000	25 in <sup>3</sup> (410 cc)	Any	(7)	12, 16, 19, 23, 27, 31, 43	✓	✓

## EQUIPMENT



## Crimpers

PC100S-RCD Portable Series

# PC100S-RCD Portable Series Crimper

The PC100S-RCD crimper can be carried to the jobsite with a handle and support stand, making this crimper ideal for portable crimping requirements. Whether carried on-site, used in a vehicle or even stationary at the shop, the PC100S-RCD is designed as a low volume crimper for occasional use. The crimp diameter is set and controlled with an easy-to-read T420 micrometer. This affordable crimper is packaged in component parts to fit the needs of the user.

The PC100S-RCD standard package includes: T420 micrometer, LED light indicator, removable pusher, standard pressure plate, Continental digital caliper, die removal magnet, and CRIMPX die lubricant oil w/ dauber cap.

## PC100S-RCD Features

### NOTCHED PRESSURE PLATE

- Ideal when crimping 90 deg. fittings



Lightweight portable crimper can be carried to almost any location where service is required



Micrometer is fully adjustable for a precise crimp



Easy Lubrication Maintenance



Crimper position can be adjusted for optimum crimping position



Open design allows the operator to accurately position the fitting prior to crimping



LED indicator light will turn on to indicate that the crimp is complete

# PC100P-RCD Portable Series Crimper

**CAPABILITY**

- (-16) B2 Fittings
- (-08) SG Fittings

**TECHNICAL DATA**

- **CRIMPING FORCE** 35 Ton
- **WEIGHT** 66 lbs. (crimper only)  
95 lbs. (crimper w/ case)
- **DIMENSIONS** 16" L x 16" W x 14-¼" H (crimper only)  
16" L x 16" W x 18" H (crimper inside case)
- **DIE SERIES** PC125RCD



SAP #	Pump	PSI	Reservoir Capacity	Country Approved	Dies Included	Die Sizes (MM)	Carrying Case Included
21063168	Pneumatic	10,000	100 cu in (1,639 cc)	Any	(7)	12, 16, 19, 23, 27, 31, 43	✓

# PC100P-RCD Portable Series Crimper

The PC100P-RCD crimper can be transported easily to the jobsite, making this crimper deal for portable crimping requirements. Whether transported on-site, used in a vehicle or even stationary at the shop, the PC100P-RCD is designed as a low volume crimper for occasional use. The crimp diameter is set and controlled with an easy-to-read T420 micrometer. This affordable crimper is packaged in component parts to fit the needs of the user.

The PC100P-RCD standard package includes: T420 micrometer, LED light indicator, removable pusher, standard pressure plate, Continental digital caliper, die removal magnet, and CRIMPX die lubricant oil w/ dauber cap.

## PC100P-RCD Features

### COMPACT ENGINEERED DESIGN

- Ideal for small workshops
- Convenient storage case to keep the crimper and crimping accessories all together
- The unit can be easily transported in vehicles for on-site jobs



Lightweight portable crimper with a convenient storage case



Crimper and crimping accessories can be stored in the case

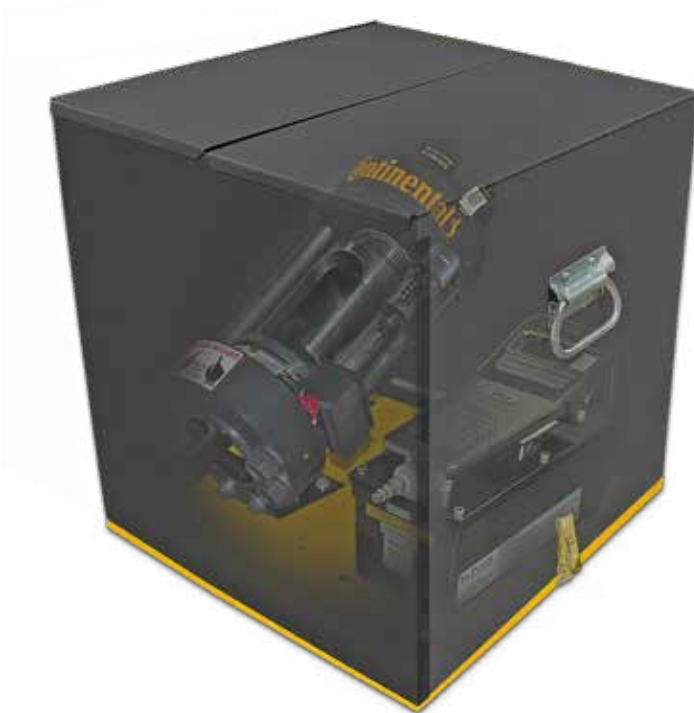

Micrometer is fully adjustable for a precise crimp



Easy Lubrication Maintenance

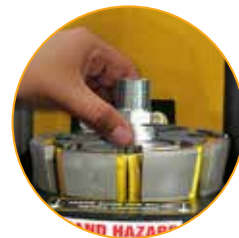

Open design allows the operator to accurately position the fitting prior to crimping



LED indicator light will turn on to indicate that the crimp is complete

# PC100H-RCD Portable Series Crimper

## CAPABILITY

- (-16) B2 Fittings
- (-08) SG Fittings

## TECHNICAL DATA

- **CRIMPING FORCE** 35 Ton
- **WEIGHT** 66 lbs. (crimper only)  
95 lbs. (crimper w/ case)
- **DIMENSIONS** 16" L x 16" W x 14-¼" H (crimper only)  
16" L x 16" W x 18" H (crimper inside case)
- **DIE SERIES** PC125RCD



SAP #	Pump	PSI	Reservoir Capacity	Country Approved	Dies Included	Die Sizes (MM)	Carrying Case Included
21063167	Hand	10,000	25 in <sup>3</sup> (410 cc)	Any	(7)	12, 16, 19, 23, 27, 31, 43	✓

## EQUIPMENT



## Crimpers

PC100H-RCD Portable Series



# PC100H-RCD Portable Series Crimper

The PC100H-RCD crimper can be transported easily to the jobsite, making this crimper ideal for portable crimping requirements. Whether transported on-site, used in a vehicle or even stationary at the shop, the PC100H-RCD is designed as a low volume crimper for occasional use. The crimp diameter is set and controlled with an easy-to-read T420 micrometer. This affordable crimper is packaged in component parts to fit the needs of the user. The PC100H-RCD standard package includes: T420 micrometer, LED light indicator, removable pusher, standard pressure plate, Continental digital caliper, die removal magnet, and CRIMPX die lubricant oil w/ dauber cap.

## PC100H-RCD Features

### COMPACT ENGINEERED DESIGN

- Ideal for small workshops
- Convenient storage case to keep the crimper and crimping accessories all together
- The unit can be easily transported in vehicles for on-site jobs



Lightweight portable crimper with a convenient storage case



Crimper and crimping accessories can be stored in the case



Micrometer is fully adjustable for a precise crimp



Easy Lubrication Maintenance

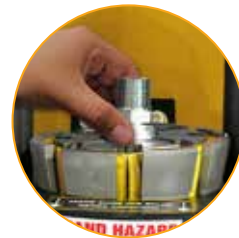

Open design allows the operator to accurately position the fitting prior to crimping

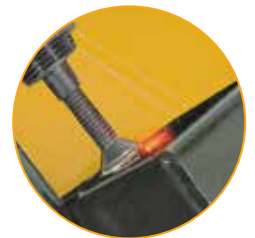

LED indicator light will turn on to indicate that the crimp is complete

# PC125M-RCD Portable Series Crimper

## CAPABILITY

- (-20) B2 Fittings
- (-16) SG Fittings



## TECHNICAL DATA

- **CRIMPING FORCE** 60 Ton
- **WEIGHT** 85 lbs. (crimper only)
- **DIMENSIONS** 17" L x 10-1/4" W x 18-1/2" H
- **DIE SERIES** PC125RCD



SAP #	Pump	PSI	Reservoir Capacity	Country Approved	Dies Included	Die Sizes (MM)	Quick Disconnect Included	Drawer/Stand Included
20821205	*None	N/A	N/A	Any	(8)	16, 19, 23, 27, 31, 34, 43, 50	✓	✓
20821206	*None	N/A	N/A	Any	(5)	16, 19, 23, 31, 41	✓	✓
20821204	*None	N/A	N/A	Any	None		✓	

\*Do not forget to buy your pump that best fits your portable crimping requirements. See the chart below.

SAP #	Pump	PSI	Reservoir Capacity	Country Approved	Pump Model
20244931	Hand	10,000	43 in <sup>3</sup> (705 cc)	Any	
20244932	Pneumatic	10,000	100 cu in (1,639 cc)	Any	
20244916	110V / 3/4HP	10,000	1 Gallon	U.S.A	

# PC125M-RCD Portable Series Crimper

The PC125M-RCD crimper can be carried to the jobsite with a handle and support stand, making this crimper ideal for portable crimping requirements. Whether carried on-site, used in a vehicle or even stationary at the shop, the PC125M-RCD is designed as a low volume crimper for occasional use. The crimp diameter is set and controlled with an easy-to-read T420 micrometer. This affordable crimper is packaged in component parts to fit the needs of the user.

The PC125M-RCD standard package includes: T420 micrometer, adjustable retraction stop, LED light indicator, removable pusher, standard pressure plate, notched pressure plate, Continental digital caliper, die removal magnet, and CRIMPX die lubricant oil w/ dauber cap.

## PC125M-RCD Features

### ADJUSTABLE RETRACTION STOP

- Limits ram retraction to only the amount required to remove the hose and coupling
- Saving time on multiple repetitive crimps



Portable rugged steel frame and strain rods provide strength, stability, and performance for all crimping service



Micrometer is fully adjustable for a precise crimp



Easy Lubrication Maintenance



Ideal notched pressure plate when crimping 90 deg. fittings



Open design allows the operator to accurately position the fitting prior to crimping



LED indicator light will turn on to indicate that the crimp is complete



# PC125-RCD Series Crimper

## CAPABILITY

- (-20) B2 Fittings
- (-16) SG Fittings

## TECHNICAL DATA

- **CRIMPING FORCE** 60 Ton
- **WEIGHT** 154 lbs. (crimper only)
- **DIMENSIONS** 22-½" L x 13" W x 22-½" H
- **DIE SERIES** PC125RCD
- **OIL CAPACITY** 1 gal.



SAP #	Voltage	Phase	Plug	Hertz	Country Approved	Dies Included	Die Sizes (MM)	Stand Drawer Included
20809573	110V	1	NEMA 5-15	60	U.S.A	(8)	16, 19, 23, 27, 31, 34, 43, 50	✓
20969061	220V	1	NEMA 6-20	60	U.S.A	(8)	16, 19, 23, 27, 31, 34, 43, 50	✓
20809574	110V	1	NEMA 5-15	60	Canada	(8)	16, 19, 23, 27, 31, 34, 43, 50	✓
20833029	110V	1	NEMA 5-15	60	U.S.A	(5)	16, 19, 23, 31, 41	✓
20888688	110V	1	NEMA 5-15	60	Canada	(5)	16, 19, 23, 31, 41	
20809571	110V	1	NEMA 5-15	60	U.S.A	None		
20809572	110V	1	NEMA 5-15	60	Canada	None		
20913958	12VDC	1	Jumper Cables	N/A	Any	None		

## EQUIPMENT



## Crimpers

PC125-RCD Series

# PC125-RCD Series Crimper

The PC125-RCD crimper with its open design, removable pusher and easy-to-use, rubber-cage die set, is designed for higher production volume and repetitive use. Crimp diameter is set and controlled with an easy-to-read T420 micrometer. The PC125-RCD is packaged for shop service.

The PC125-RCD standard package includes: T420 micrometer, electronic stop switch, adjustable retraction stop, removable pusher, standard pressure plate, notched pressure plate, adjustable coupling stop, pneumatic start/stop pendant switch, Continental digital caliper, die removal magnet, and CRIMPX die lubricant oil w/ dauber cap.

## PC125-RCD Features

### PC125 STAND/DRAWER

- The PC125-RCD crimper can be mounted on the PC125 Stand/Drawer
- PC125-RCD dies and crimping tooling can be stored in the drawer



Micrometer is fully adjustable for a precise crimp



Easy Lubrication Maintenance



Ideal notched pressure plate when crimping 90 deg. fittings



Retraction Stop limits ram retraction for quick repetitive crimps



Coupling Stop makes repetitive crimps faster



Electronic Stop Switch shuts the pump off when the crimp cycle is complete

# PC125PS (Positive Stop) Series Crimper

## CAPABILITY

- (-16) B2 Fittings

**Compatible only with the following hose:**  
SR1SN, SR2SN, SR/XR/ARC16SC, SCP3,  
XCP3, FPII, SR/AR12 and HR4

## TECHNICAL DATA

- **CRIMPING FORCE** 60 Ton
- **WEIGHT** 150 lbs. (crimper only)
- **DIMENSIONS** 22-½" L x 13" W x 22-½" H
- **DIE SERIES** PC125RCD
- **OIL CAPACITY** 1 gal.



SAP #	Voltage	Phase	Plug	Hertz	Country Approved	Dies Included	Die Sizes (Inches)	Spacers Included	Spacers Sizes (Inches)
20871410	110V	1	NEMA 5-15	60	U.S.A	(8)	.650, .785, .930, 1.120, 1.260, 1.410, 1.610, 1.680	(11)	.085, .110, .130, .145, .160, .175, .190, .220, .250, .300, .400
20888687	220V	1	NEMA 6-20	60	Canada	(8)	.650, .785, .930, 1.120, 1.260, 1.410, 1.610, 1.680	(11)	.085, .110, .130, .145, .160, .175, .190, .220, .250, .300, .400
20815352	110V	1	NEMA 5-15	60	U.S.A	None		None	

## EQUIPMENT



## Crimpers

PC125PS Series

# PC125PS (Positive Stop) Series Crimper

The PC125PS is a Positive Stop crimper capable of crimping 2-wire braid hose and 4-wire spiral hose up through 1" ID. The crimp diameter is controlled through the use of specific die and spacer combinations. The PC125PS is packaged for shop service.

The PC125PS standard package includes: Adjustable retraction stop, removable pusher, standard psw pressure plate, (psw notched pressure plate only for SAP# 20871410), adjustable coupling stop, pneumatic start/stop pendant switch, Continental digital caliper, die removal magnet, and CRIMPX die lubricant oil w/ dauber cap.

## PC125PS Features

### PC125PS TOOLING

- Easy to use crimping tooling
- Only requires specific die and spacer within specifications to crimp the hose assembly



Crimp diameter is controlled by specific die and spacer combinations



Easy Lubrication Maintenance

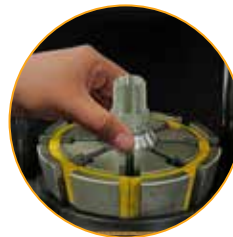

Open design allows the operator to accurately position the fitting prior to crimping



Ideal notched pressure plate when crimping 90 deg. fittings



Retraction Stop limits ram retraction for quick repetitive crimps



Crimper can be mounted on the PC125 Stand/Drawer dies & crimping tools can be stored