



The FIRG Flat Face Series, the original ISO 16028 interchangeable coupling, continues to offer good performance, long life and competitive pricing. The integrated sealing mechanism greatly reduces premature wear caused by movement between coupler and nipple parts affected by impulse pressure and the weight of the hoses and tubing when the coupling is in the horizontal position.



Protective Caps & Plugs – page 22
Repair Kits – page 23

FEATURES

Size range: 1/4" thru 2"
Port options: NPT, SAE, BSP
Interchanges with ISO 16028
Working pressure: 20-30 MPa/2900-4350 psi range

- Non-spill design avoids fluid loss during connection/disconnection
- Minimal air inclusion during connection
- Tight tolerances ensure equal loading of couplers

APPLICATIONS

Anywhere fluid loss and hydraulic circuit contamination need to be reduced or eliminated

- Mobile construction, agriculture and mining operations
- General industrial plants



PRESSURE DROP

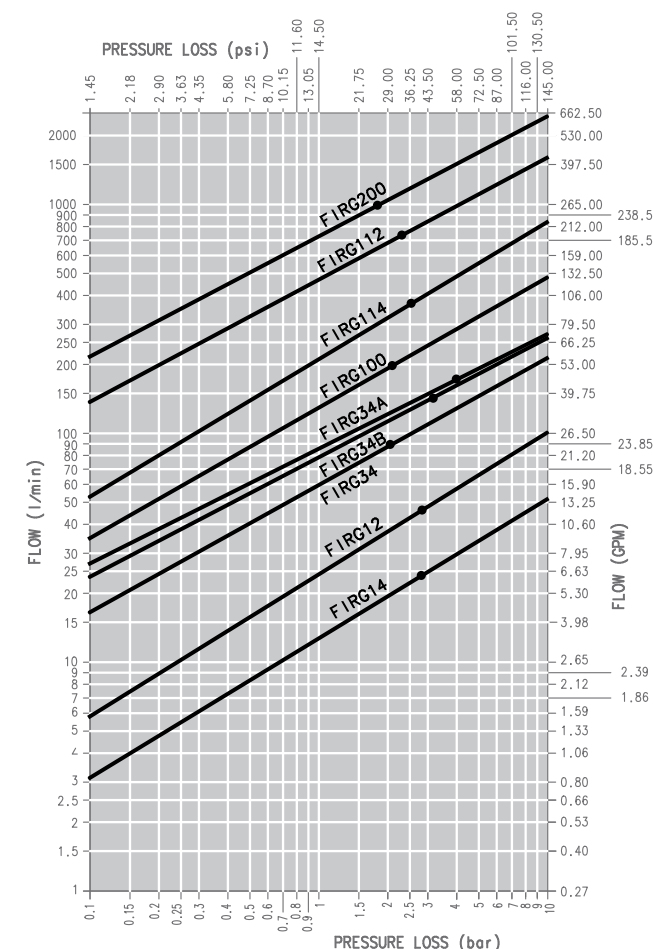

OIL = ISO VG32, TEMP = 40C, VISCOSITY = 28.8-35.2 MM²/S

Flat face valves w/ safety lock to prevent accidental disconnection

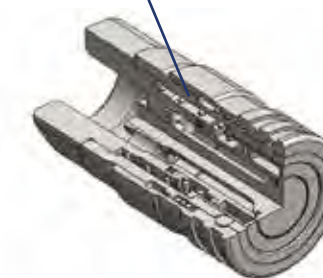

Swaged and PTFE 'U' seals for high resistance against extrusion

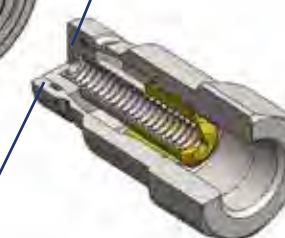

Hardened surface area & locking balls reduce brinelling

PERFORMANCE

DESCRIPTION	SIZE	ISO SIZE	MAX. OPERATING PRESSURE COUPLED		COUPLED		BURST PRESSURE			SPILLAGE*	
			MPa	psi	MPa	psi	MALE MPa	psi	FEMALE MPa		psi
FIRG14	1/4	6.3	30	4350	120	17400	126	18270	48	6960	0.006
FIRG38-12	3/8	10.0	30	4350	120	17400	120	17400	48	6960	0.012
FIRG12A-34	1/2	12.5	25	3625	100	14500	100	14500	40	5800	0.020
FIRG34B	5/8	16.0	25	3625	100	14500	88	12760	40	5800	0.026
FIRG34A	3/4	19.0	33	4785	100	14500	100	14500	100	14500	0.032
FIRG100	3/4	19.0	25	3625	100	14500	80	11600	40	5800	0.032
FIRG114	1	25.0	25	3625	100	14500	80	11600	40	5800	0.035
FIRG112	1 1/2	-	20	2900	80	11600	80	11600	32	4640	0.050
FIRG200	2	-	20	2900	80	11600	64	9280	32	4640	0.100

* Spillage is an indicative value of the fluid loss per couple-uncouple cycle.



SIZE DIAGRAM

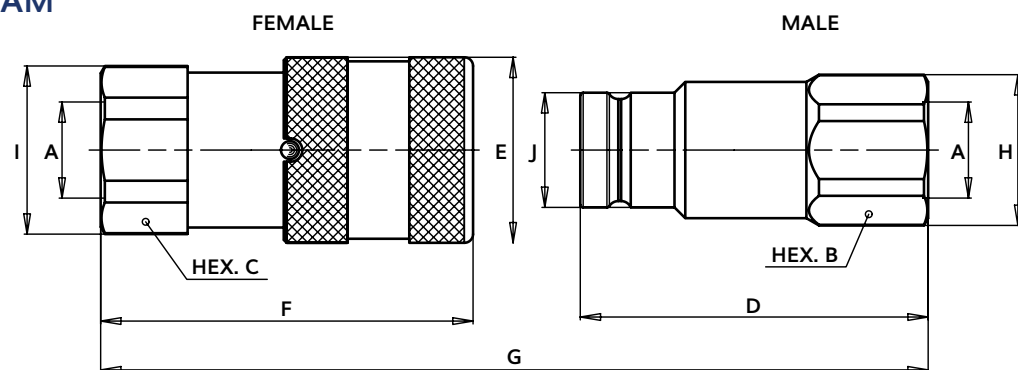

DESCRIPTION	BODY SIZE	A	UNIT											WEIGHT	
				B	C	D	E	F	G	H	I	J	UNIT	MALE	FEMALE
FIRG14	1/4	1/4	mm	22.0	22.0	47.9	28.0	48.1	85.2	23.8	23.8	16.1	kg	0.086	0.140
			inch	0.87	0.87	1.89	1.10	1.89	3.35	0.94	0.94	0.63	lb	0.19	0.31
FIRG38	3/8	3/8	mm	24.0	27.0	60.0	32.0	64.2	108.7	26.0	29.0	19.7	kg	0.121	0.235
			inch	0.94	1.06	2.36	1.26	2.53	4.28	1.02	1.14	0.78	lb	0.27	0.52
FIRG12	3/8	1/2	mm	27.0	27.0	62.5	32.0	69.2	116.2	29.0	29.0	19.7	kg	0.128	0.237
			inch	1.06	1.06	2.46	1.26	2.72	4.57	1.14	1.14	0.78	lb	0.28	0.52
FIRG12A	1/2	1/2	mm	32.0	32.0	68.0	38.0	73.8	124.5	33.8	33.8	24.5	kg	0.233	0.375
			inch	1.26	1.26	2.68	1.50	2.91	4.90	1.33	1.33	0.96	lb	0.51	0.83
FIRG34	1/2	3/4	mm	36.0	36.0	70.5	38.0	80.8	134.0	38.5	38.5	24.5	kg	0.227	0.413
			inch	1.42	1.42	2.78	1.50	3.18	5.28	1.52	1.52	0.96	lb	0.50	0.91
FIRG34B	5/8	3/4	mm	36.0	36.0	70.5	42.0	78.5	131.4	38.5	38.5	27.0	kg	0.268	0.479
			inch	1.42	1.42	2.78	1.65	3.09	5.17	1.52	1.52	1.06	lb	0.59	1.06
FIRG34A	3/4	3/4	mm	41.0	41.0	82.3	48.0	88.7	149.0	44.8	44.8	30.0	kg	0.445	0.750
			inch	1.61	1.61	3.24	1.89	3.49	5.87	1.76	1.76	1.18	lb	0.98	1.65
FIRG100	3/4	1	mm	45.0	45.0	82.3	48.0	93.2	153.5	47.8	47.8	30.0	kg	0.394	0.767
			inch	1.77	1.77	3.24	1.89	3.67	6.04	1.88	1.88	1.18	lb	0.87	1.69
FIRG114	1	1 1/4	mm	55.0	55.0	89.8	55.0	106.0	172.8	59.8	59.8	36.0	kg	0.641	1.215
			inch	2.17	2.17	3.54	2.17	4.17	6.80	2.35	2.35	1.42	lb	1.41	2.68
FIRG112	1 1/2	1 1/2	mm	65.0	65.0	111.1	80.0	132.4	214.9	69.8	72.0	57.0	kg	1.665	2.820
			inch	2.56	2.56	4.37	3.15	5.21	8.46	2.75	2.83	2.24	lb	3.67	6.22
FIRG200	2	2	mm	75.0	80.0	123.8	100.0	156.6	241.5	83.5	88.5	73.0	kg	2.259	5.100
			inch	2.95	3.15	4.87	3.94	6.17	9.51	3.29	3.48	2.87	lb	4.98	11.24

FIRG Series Accessories Coupler Dust Cap | Nipple Dust Cap

BODY SIZE	PORT SIZE	ORDER CODE	DESCRIPTION	
			COUPLER / FEMALE DUST CAP	NIPPLE / MALE DUST CAP
1/4	1/4	815100000	CAP F. FIRG14/A7	815100001 CAP M. FIRG14/A7
3/8	3/8	-	-	815100003 CAP M. FIRG38/A9
3/8	3/8 & 1/2	815100002	CAP F. FIRG38/A9/FIRG12	815100005 CAP M. FIRG12/A9
1/2	1/2	815100004	CAP F. FIRG12A/A13	815100007 CAP M. FIRG12A/A13
1/2	1/2 & 3/4	815100006	CAP F. FIRG34/A13	815100009 CAP M. FIRG34/A13
5/8	3/4	815100008	CAP F. FIRG34B/A15	815100011 CAP M. FIRG34B/A15
3/4	3/4	815100010	CAP F. FIRG100/A17	815100013 CAP M. FIRG100/A17
1	1	815100012	CAP F. FIRG114/A21	815100015 CAP M. FIRG114/A21
1 1/4	1 1/4	815205020	CAP F. A25	815205021 CAP M. A25
1 1/2	1 1/2	815100014	CAP F. FIRG112/A30	815100017 CAP M. FIRG 112/A30
2	2	815100016	CAP F. FIRG 200	815100019 CAP M. FIRG 200



Female Cap



Male Cap

Additional colors available upon request

FIRG NPT and SAE Thread ISO 16028

PART	BODY SIZE	PORT SIZE	THREAD TYPE	ORDER CODE	PART DESCRIPTION
FIRG NPT THREAD					
COUPLER	1/4	1/4	NPT	800801000	F. FIRG 14 NPT
NIPPLE	1/4	1/4	NPT	800801001	M. FIRG 14 NPT
COUPLER	3/8	1/2	NPT	800801002	F. FIRG 12 NPT
NIPPLE	3/8	1/2	NPT	800801003	M. FIRG 12 NPT
COUPLER	3/8	3/8	NPT	800801004	F. FIRG 38 NPT
NIPPLE	3/8	3/8	NPT	800801005	M. FIRG 38 NPT
COUPLER	1/2	1/2	NPT	800801006	F. FIRG 12AD NPT
NIPPLE	1/2	1/2	NPT	800801007	M. FIRG 12A NPT
COUPLER	1/2	3/4	NPT	800801008	F. FIRG 34D NPT
NIPPLE	1/2	3/4	NPT	800801009	M. FIRG 34 NPT
COUPLER	5/8	3/4	NPT	800801010	F. FIRG 34BD NPT
NIPPLE	5/8	3/4	NPT	800801011	M. FIRG 34B NPT
COUPLER	3/4	3/4	NPT	800801020	F. FIRG 34A NPT
NIPPLE	3/4	3/4	NPT	800801021	M. FIRG 34A NPT
COUPLER	3/4	1	NPT	800801012	F. FIRG 100 NPT
NIPPLE	3/4	1	NPT	800801013	M. FIRG 100 NPT
COUPLER	1	1 1/4	NPT	800801014	F. FIRG 1 1/4 NPT
NIPPLE	1	1 1/4	NPT	800801015	M. FIRG 1 1/4 NPT
COUPLER	1 1/2	1 1/2	NPT	800801016	F. FIRG 1 1/2 NPT
NIPPLE	1 1/2	1 1/2	NPT	800801017	M. FIRG 1 1/2 NPT
COUPLER	2	2	NPT	800801018	F. FIRG 200 NPT
NIPPLE	2	2	NPT	800801019	M. FIRG 200 NPT
FIRG SAE THREAD					
COUPLER	1/4	3/8	SAE	800804000	F. FIRG 14 3/8 SAE
NIPPLE	1/4	3/8	SAE	800804001	M. FIRG 14 3/8 SAE
COUPLER	3/8	1/2	SAE	800804002	F. FIRG 38 1/2 SAE
NIPPLE	3/8	1/2	SAE	800804003	M. FIRG 38 1/2 SAE
COUPLER	3/8	5/8	SAE	800804004	F. FIRG 12 5/8 SAE
NIPPLE	3/8	5/8	SAE	800804005	M. FIRG 12 5/8 SAE
COUPLER	1/2	5/8	SAE	800804006	F. FIRG 12A 5/8 SAE
NIPPLE	1/2	5/8	SAE	800804007	M. FIRG 12A 5/8 SAE
COUPLER	1/2	3/4	SAE	800804008	F. FIRG 34D SAE
NIPPLE	1/2	3/4	SAE	800804009	M. FIRG 34 SAE
COUPLER	5/8	3/4	SAE	800804010	F. FIRG 34BD SAE
NIPPLE	5/8	3/4	SAE	800804011	M. FIRG 34B SAE
COUPLER	3/4	3/4	SAE	800804020	F. FIRG 34A SAE
NIPPLE	3/4	3/4	SAE	800804021	M. FIRG 34A SAE
COUPLER	3/4	1	SAE	800804012	F. FIRG 100 SAE
NIPPLE	3/4	1	SAE	800804013	M. FIRG 100 SAE
COUPLER	1	1 1/4	SAE	800804014	F. FIRG 1 1/4 SAE
NIPPLE	1	1 1/4	SAE	800804015	M. FIRG 1 1/4 SAE
COUPLER	1 1/2	1 1/2	SAE	800804016	F. FIRG 1 1/2 SAE
NIPPLE	1 1/2	1 1/2	SAE	800804017	M. FIRG 1 1/2 SAE
COUPLER	2	2	SAE	800804018	F. FIRG 200 SAE
NIPPLE	2	2	SAE	800804019	M. FIRG 200 SAE



Coupler



Nipple

Repair Kits

ORDER CODE	DESCRIPTION
FIRG SERIES	
815700001	KIT M. FIRG 14
815700003	KIT M. FIRG 38/12
815700005	KIT M. FIRG 12A/34
815700007	KIT M. FIRG 34B
815700009	KIT M. FIRG 100
815700011	KIT M. FIRG 114
815700013	KIT M. FIRG 112
815700015	KIT M. FIRG 200

